

LBHP6 Datasheet

Intelligent reflex light barrier



1 General Description

- IR-light barrier, for 100 – 200 mm adjustable operation distance
- Infrared transmitter / receiver
- Natural light blocking filter, largely independent of daylight influences
- Low side switch output driver
- Wireless configuration over infrared interface for factory calibration
- Operation temperature range between -40°C – +55°C (short-term +15°C)
- 24 V +/- 30% input voltage according to EN 50155
- Complies to EN 50155
- Complies to EN 45545-2

2 Applications, Intended Use

- Detection of human hands within a factory preset distance and output of a signal to control hand wash systems in rolling stock applications

3 Mechanical characteristics

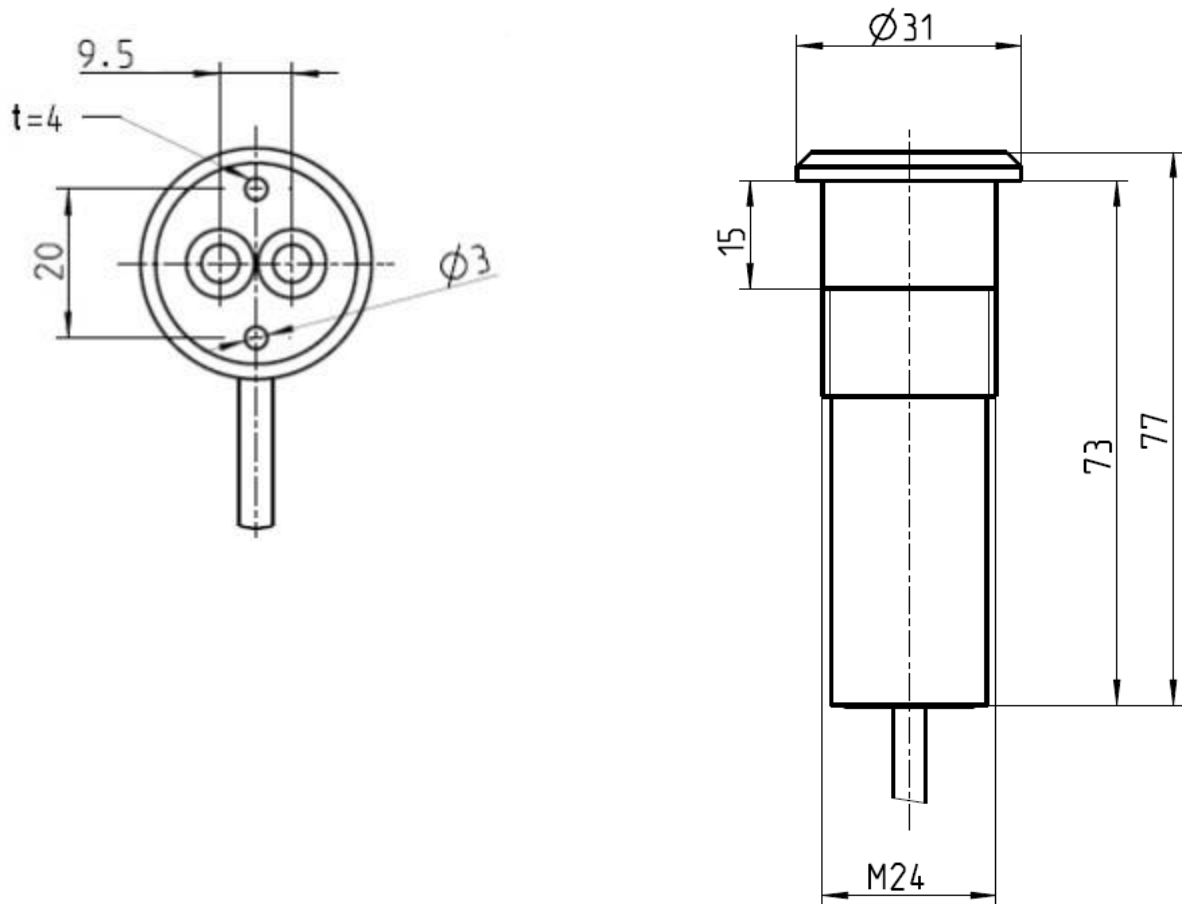

Technical data	
Diameter x Length	Ø 31 x 77mm
Distance / Diameter of tool attachment	20mm / 3mm
Max. depth / Diameter of mounting hole	14mm / 29mm
Housing material	Aluminium
Casting compound	Bectron casting compound PU 4534, polyurethane resin based
Colour of housing	Colourless anodised
Thread	M24 x 1.5; L=26mm
Weight	135g±10g ¹ with cable, amp-plug, nut and washer
IP class	IP65 (excl. external connector interface)

¹ incl. cable, standard connector housing, nut, washer and ferrite sleeve

Screw nut	
Equivalent standard	ISO 8675
Type of screw thread	M24x1.5
Wrench size	36mm
Property class	70
Min. - max. locking torque	The locking torque should be in the range of 10-15Nm, recommended is 12Nm. The values are valid only with supplied washer.
Weight	58g ± 5g
Materials	Stainless steel A2

Flat washer	
Equivalent standard	DIN 125
Outer diameter	44mm
Inner diameter	25mm
Width	4mm
Weight	5g ± 1g
Materials	Polyamide

4 Electrical characteristics

Feature	Description
Power supply	24 VDC ± 30%, reverse-polarity protected
Interruption of power supply	≤10ms (Class S2 acc. EN 50155)
Supply change over	0.6 U _N <100ms (Class C1 acc. EN 50155)
Current consumption	Average 10mA (5mA inactive – 15mA active), peak 250mA w/o output load
Output	24 VDC low side switch / 1A to ground Integrated overload protection

Pin Assignment	
1	+24V DC
2	Ground
3	signal output
4	n.c.

Cable	
Length	200 mm
Diameter	4.9 mm \pm 0.5mm
Conductor count and cross section	3 x 0.75mm ²
Bending radius	\geq 5 x Diameter
Conductor material	Cu tin-plated

Plug AMP Mini Universal-MATE-N-LOK²	
article no.	172167-1
plug gender	male
pin count	4
pin contact	AMP Mini-Mate-N-Lok 170364-1
single conductor cross section	(0.3 - 0.89)mm ²

Plug AMP Mini Universal-MATE-N-LOK² – Water proofed	
article no.	794939-1
plug gender	female
pin count	4
pin contact	crimp contact AMP Mini-Universal MATE-N-LOK 770988-1
single conductor cross section	(0.3-0.89)mm ²
gasket	AMP Mini Universal Mate-N-Lok 794772-4
conductor gasket	AMP Mini Universal Mate-N-Lok 794758-1
blind pin	AMP Mini Universal Mate-N-Lok 794995-1

² Other connector types available

5 Environment characteristic

Feature	Description
Storage temperature	-40°C .. +85°C
Operating temperature	-40°C .. +55°C (Class OT2 acc. EN 50155)
Extended operating temperature	+70°C (Class ST1 acc. EN 50155)
Storage humidity	max. 95%, non-condensing
Operating humidity	max. 95%, non-condensing
Altitude range	max. 1400m (Class A1 acc. EN 50125-1)
Shock / Vibration	Category 1 Class B (acc. EN 61373)

Life cycle data	
Useful life	>10 years (Class L2 acc. EN 50155)
Warranty	1 year

6 Optical characteristic

Properties	Description
Range	100-200mm ± 15mm operation distance ³
Filter	Natural light blocking filter

6.1 Ambient light characteristics

The detection range of the LBHP6 is nearly constant at diffuse ambient light conditions. The LBHP6 should not be used on direct illumination with IR-active lights within a radiation angle of < 10°.

³ The detection range is a factory preset.

7 Standards

Applied Standards	
2014/30/EU	EU directive electromagnetic compatibility
EN 50155	Railway application - Electronic equipment used on rolling stock
EN 50121-3-2	Railway applications - Electromagnetic compatibility - Part 3-2: Rolling stock - Apparatus
EN 50124-1	Railway applications - Insulation coordination – Part 1: Basic requirements - Clearance and creepage distances
EN 50153	Railway applications - Rolling stock - Protective provisions relating to electrical hazards
EN 45545-2	Fire protection on railway vehicles – Part 2: Requirements for fire behaviour of materials and components
EN 61373	Railway applications - Rolling stock equipment - Shock and vibration tests
EN 60529	Degrees of protection provided by enclosures (IP Code)

8 Installation

The tripping characteristic of the light barrier depends on its installation. The detection area of the sensor can contain the following situations:

- a) detection area outside of the water jet and outside of the hand washing position
 - b) detection area out of the water jet and within the hands washing position
- It is important that the sensor area of the light barrier is not adjusted to reflective surfaces such as stainless steel tanks, other metallic objects or water surfaces to address faulty activation
On strong reflective and curved surfaces in the longitudinal axis of the sensor the LBHP6 must be moved laterally and / or be tilted
 - The horizontal mounting position of the front sensor / emitter unit is recommended
 - The tripping distance from the hand position is configured by factory default
 - It is not recommended to set the detection area within the water jet above the basin

We recommend installation situation b.

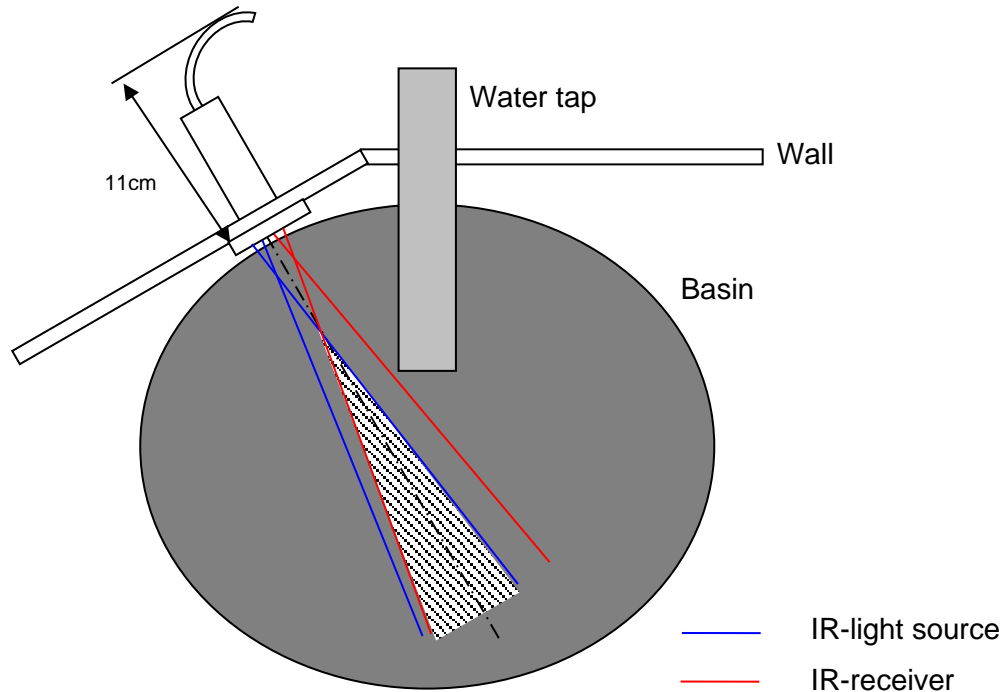

9 Parameters

Parameter	Range	Resolution	Typical value	Note
Sensitivity	10..90 %	1%	/	detection range, additional preselection far / near-options available
Start delay	0..4 sec	0.05 sec	0.3 sec	Output signal delay after detection
Follow-up-time	0..15 sec	0.05 sec	3.0 sec	activation time of output, after no object is detected
Uptime	0..1600 sec	0.05 sec	10 sec	maximum activation time of the output signal of persistent detection of an object
Locking time	0; 0.2..1600 sec	0.05 sec	1 sec	This is the time step after the expiration of the maximum runtime in which no new objects can be detected
Release time	0..1600 sec	0.05 sec	0.5 sec	time after the locking time in which no new activation can take place

10 Maintenance

The LBHP6 is free of regular maintenance.

11 Cleaning

- Neutral cleaning agent and warm water may be used for cleaning purpose
- Make sure that the cleaner not reacts with epoxy cast resin
- Do not use abrasive cleaning options
- Remove cleaning material after use
- The LED's should be free of cleaning residues

12 Accessory

- Mounting Tool
- Programming Adapter (IR → COM)
- Programming Software

13 Delivery, Packaging and Labelling

- The LBHP6 is pre-assembled with connector, nut and washer.
- The LBHP6 is packed in a bubble bag.
- The LBHP6 comes normally in quantities of 1 piece in a cardboard box.
- Other packaging units are possible on request.
- The LBHP6 is labelled with name, serial number and can be applied with customer related article number and technical values of the light barrier. Custom specific labelling is possible on request.

14 Contact

m-u-t GmbH ♦ Am Marienhof 2 ♦ D-22880 Wedel ♦ Germany

Fon: +49 (0)4103 / 93 08-0

Fax: +49 (0)4103 / 93 08-99

Internet: <http://www.mut-group.com>

Email: info@mut-group.com